

CPC 135-12

Cyclic battery

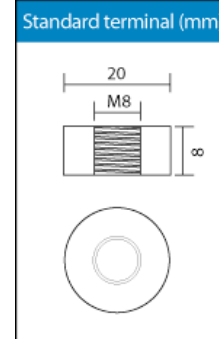
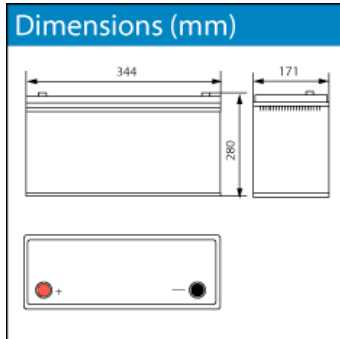

Nominal voltage	12 V DC	
Nominal Capacity (10HR, 20°C):	135 Ah	
Nominal Capacity (20HR, 20°C):	144,8 Ah	
Internal resistance	Approx. 4 m Ω	
Maximum charging current	40,5 A	
Maximum discharge current	3038 A (5 sec.)	
Operating temperature range	-20°C ~ 50°C	
Float use/ cycle use	13,6 – 13,8V/ 14,5 – 14,9V	
Standard terminal	Threaded Insert 8mm	
Housing material	ABS FR GLASS HB	
Dimensions	length	344 mm (±3 mm)
	width	171 mm
	height	280 mm (±1 mm)
Approx. Weight	46,3 kg	
Packing	1 pcs/box	

Typical applications:

- Wheelchairs
- Lawnmower
- Vacuum cleaner
- Medical
- Equipment
- Toys

- Valve Regulated Maintenance Free
- Absorbent Glassmat Technology
- Built to comply with DIN 43534, IEC896-2, BS6290-pt.4, EUROBAT
- Low self discharge
- Classified as non- spillable and Non Dangerous goods by IATA, FAA, ADR, IMDG
- Can be discharged or stored in any position without leakage
- Cannot be charged while the terminal is downward.

Charging characteristics

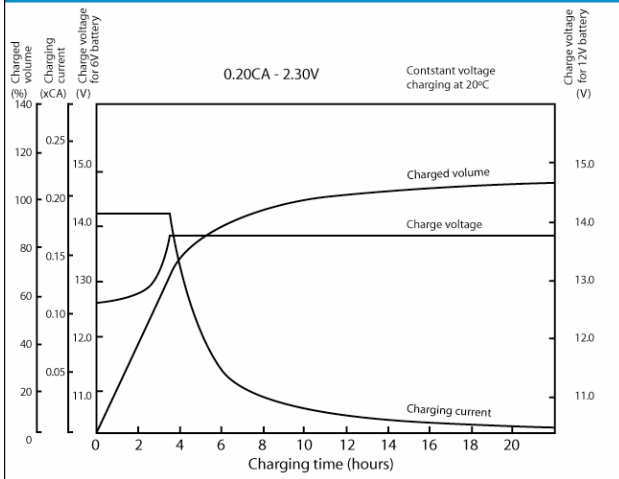

Discharge characteristics curves

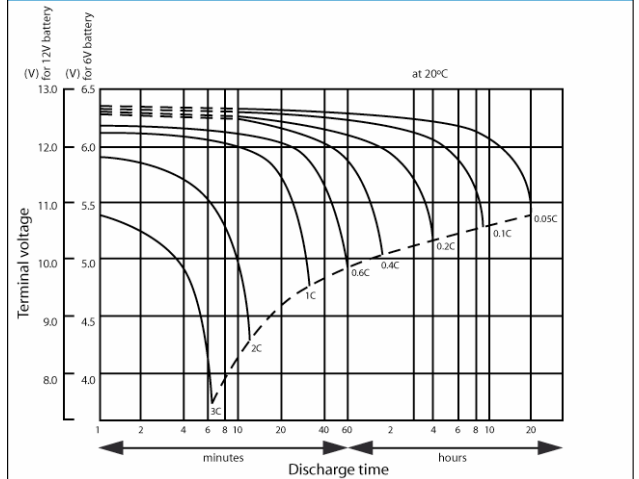

Relationship between charging voltage and temperature

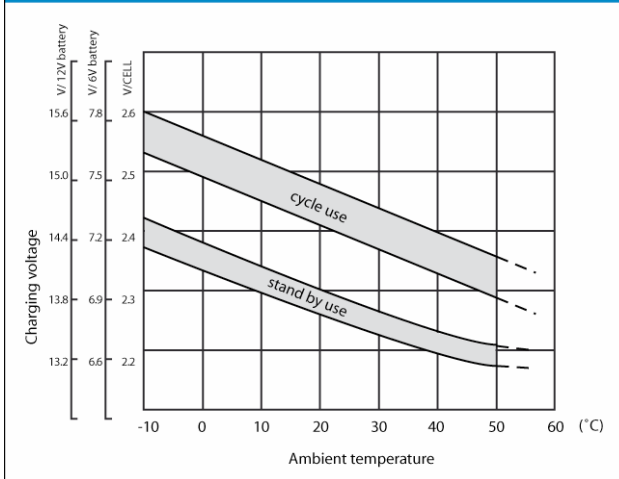

Cycle service life in relation to depth and discharge

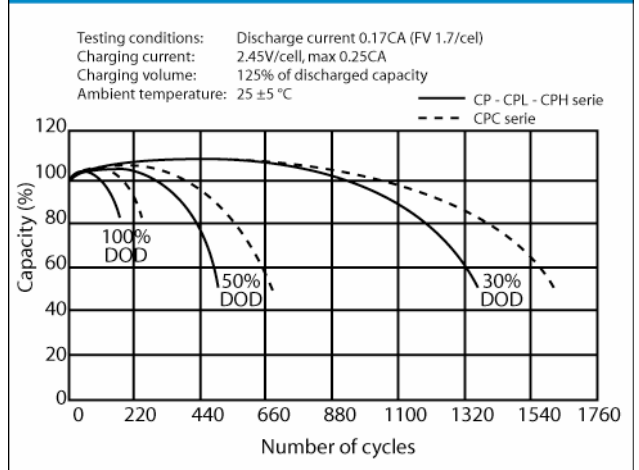

Models available

Model	capacity (Ah)	Dimensions (mm)	weight
CPC 9 - 12	9	151 x 65 x 100	2.6 kg
CPC 10 - 12	10	151 x 65 x 111	3.5 kg
CPC 12 - 12	12	151 x 98 x 101	3.7 kg
CPC 18 - 12	18	181,5 x 77 x 167,5	6 kg
CPC 24 - 12	24	166,5 x 175 x 125	8.9 kg
CPC 24 - 12G	24	166,5 x 175 x 125	8.9 kg
CPC 33 - 12	33	195 x 130 x 180	11.2 kg
CPC 38 - 12	38	197 x 165 x 170	14.5 kg
CPC 55 - 12	55	228 x 138 x 208	19 kg
CPC 60 - 12	60	278 x 175 x 190	21.5 kg
CPC 75 - 12	75	259 x 168 x 208	23.3 kg
CPC 90 - 12	90	306 x 173 x 212	29 kg
CPC 110 - 12	110	330 x 173 x 220	31 kg
CPC 120 - 12	120	410 x 177 x 225	35 kg
CPC 135 - 12	135	344 x 171 x 280	46,3 kg
CPC 150 - 12	150	485 x 170 x 242	43 kg
CPC 160 - 12	160	530 x 209 x 214	41 kg
CPC 200 - 12	200	522 x 240 x 224	61 kg