

**CPC 110-12I**

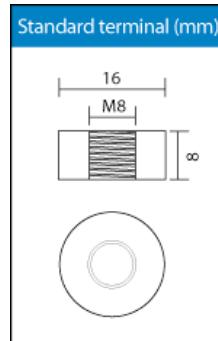

**Cyclic battery**

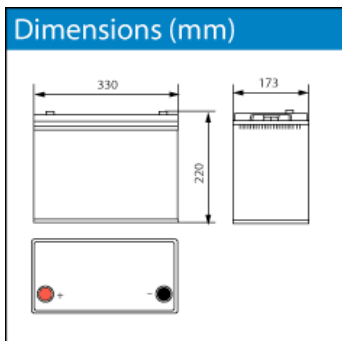

Nominal voltage	12 V DC	
Nominal Capacity (10HR, 20°C):	110 Ah	
Nominal Capacity (20HR, 20°C):	116 Ah	
Internal resistance	Approx. 4,5 m Ω	
Maximum charging current	33 A	
Maximum discharge current	1430 A (5 sec.)	
Operating temperature range	-20°C ~ 50°C	
Float use/ cycle use	13,6 – 13,8V/ 14,5 – 14,9V	
Standard terminal	Threaded Insert 8mm	
Housing material	ABS FR GLASS HB	
Dimensions	length	330 mm
	width	173 mm
	height	220 mm (±1 mm)
Approx. Weight	31 kg	
Packing	1 pcs/box	

- Typical applications:**
- Wheelchairs
  - Lawnmower
  - Vacuum cleaner
  - Medical
  - Equipment
  - Toys

- Valve Regulated Maintenance Free
- Absorbent Glassmat Technology
- Built to comply with DIN 43534, IEC896-2, BS6290-pt.4, EUROBAT
- Low self discharge
- Classified as non- spillable and Non Dangerous goods by IATA, FAA, ADR, IMDG
- Can be discharged or stored in any position without leakage
- Cannot be charged while the terminal is downward.

### Charging characteristics

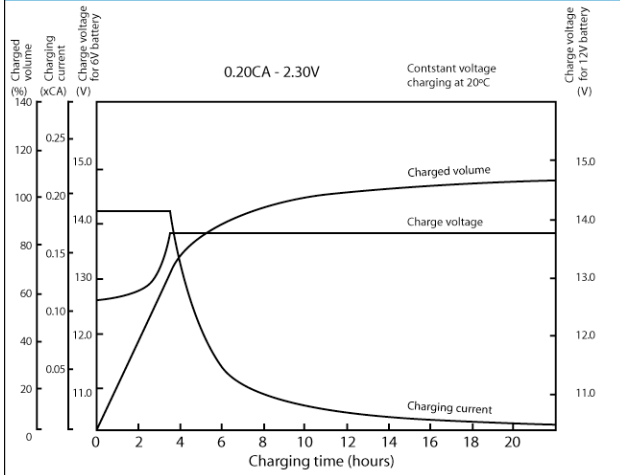

### Discharge characteristics curves

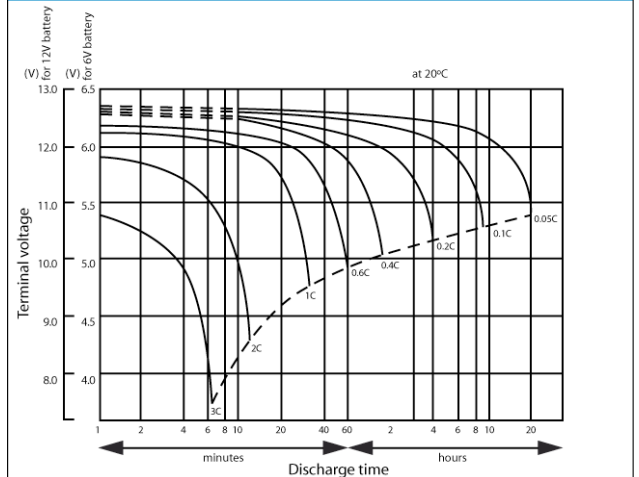

### Relationship between charging voltage and temperature

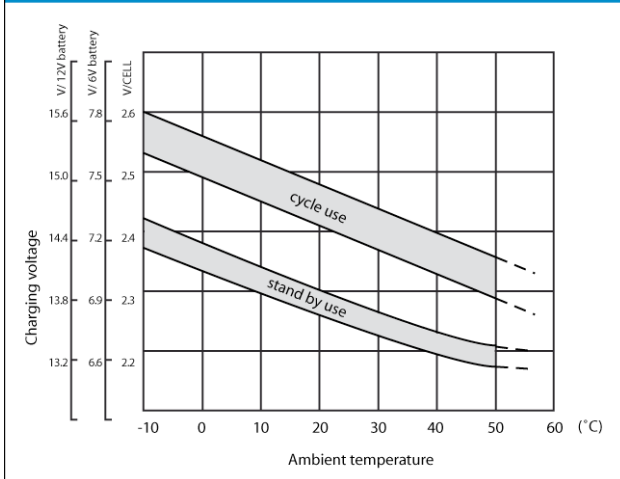

### Cycle service life in relation to depth and discharge

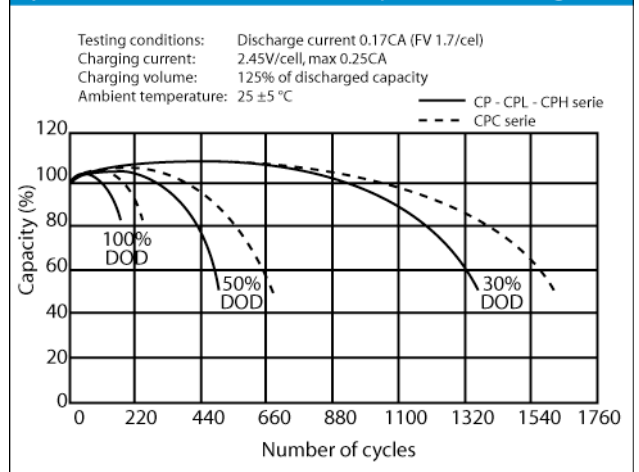

### Models available

Model	capacity (Ah)	Dimensions (mm)	weight
CPC 9 - 12	9	151 x 65 x 100	2.6 kg
CPC 10 - 12	10	151 x 65 x 111	3.5 kg
CPC 12 - 12	12	151 x 98 x 101	3.7 kg
CPC 18 - 12	18	181,5 x 77 x 167,5	6 kg
CPC 24 - 12	24	166,5 x 175 x 125	8.9 kg
CPC 24 - 12G	24	166,5 x 175 x 125	8.9 kg
CPC 33 - 12	33	195 x 130 x 180	11.2 kg
CPC 38 - 12	38	197 x 165 x 170	14.5 kg
CPC 55 - 12	55	228 x 138 x 208	19 kg
CPC 60 - 12	60	278 x 175 x 190	21.5 kg
CPC 75 - 12	75	259 x 168 x 208	23.3 kg
CPC 90 - 12	90	330 x 173 x 212	29 kg
CPC 110 - 12	110	330 x 173 x 220	31 kg
CPC 150 - 12	150	485 x 170 x 242	43 kg
CPC 160 - 12	160	530 x 209 x 214	41 kg
CPC 200 - 12	200	522 x 240 x 224	61 kg

### VdS approved VRLA batteries:

The VdS-approved Cellpower batteries form a special range that has been tested and qualified by the German VdS institute. The concept behind VdS recognition; ensuring tested and certified quality in the products and services being offered in the safety and security markets, is of equally advantageous for user and supplier.

Safety and security systems are approved by the VdS and monitored in subsequent use to protect property and life and help to keep a insurance premiums lower.

Apart from the VdS approval, this range is also approved by the Dutch NCP institute, further underlining the high quality of this range.

### Typical applications:

- VdS & NCP approved alarm systems
- Fire & burglar alarm systems