

CPC 10-12

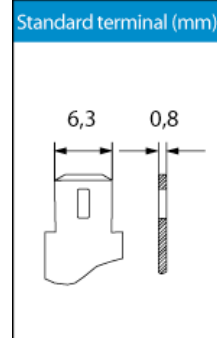

Cyclic battery

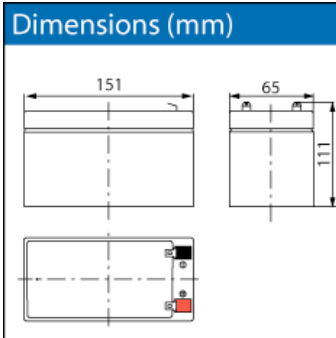

Nominal voltage	12 V DC	
Nominal Capacity (10HR,20°C):	10 Ah	
Nominal Capacity (20HR,20°C):	10,6 Ah	
Internal resistance	Approx. 20 m Ω	
Maximum charging current	3 A	
Maximum discharge current	150 A (5 sec.)	
Operating temperature range	-20°C ~ 50°C	
Float use/ cycle use	13,6 – 13,8V/ 14,5 – 14,9V	
Standard terminal	Faston 6,3 mm	
Housing material	ABS FR GLASS HB	
Dimensions	length	151 mm
	width	65 mm
	height	111 mm (±1 mm)
Approx. Weight	3,5 kg	
Packing	6 pcs/box	

Typical applications:

- Wheelchairs
- Lawnmower
- Vacuum cleaner
- Medical
- Equipment
- Toys

- Valve Regulated Maintenance Free
- Absorbent Glassmat Technology
- Built to comply with DIN 43534, IEC896-2, BS6290-pt.4, EUROBAT
- Low self discharge
- Classified as non- spillable and Non Dangerous goods by IATA, FAA, ADR, IMDG
- Can be discharged or stored in any position without leakage
- Cannot be charged while the terminal is downward.

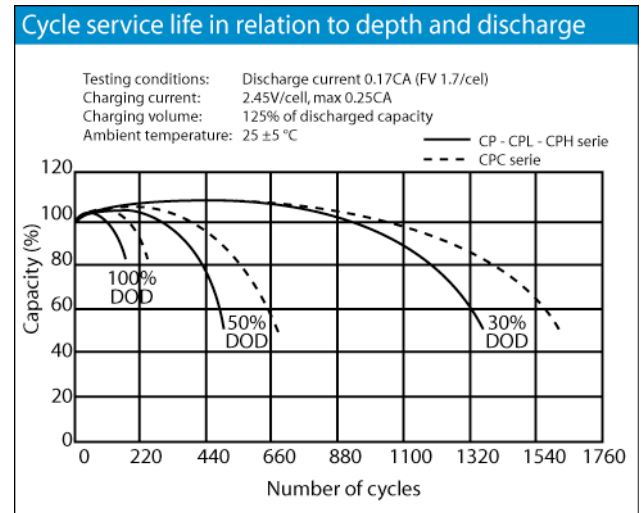
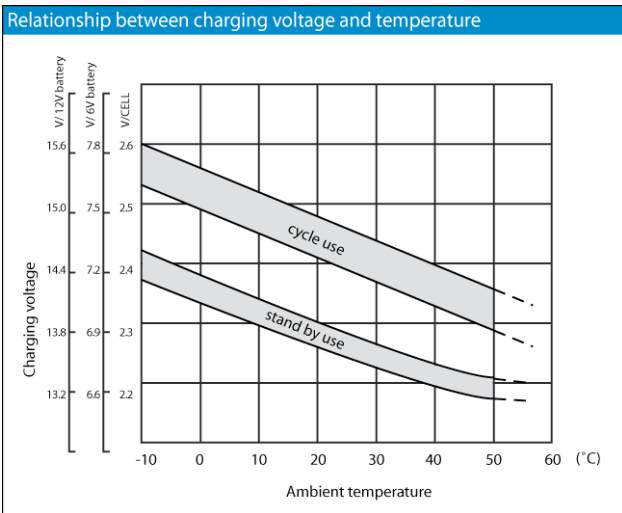
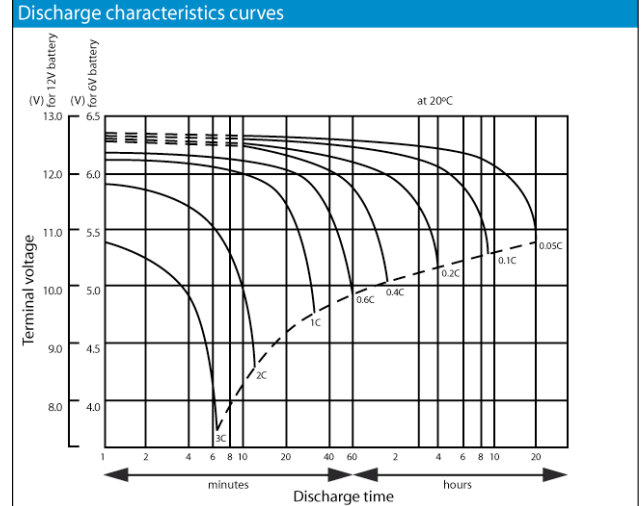
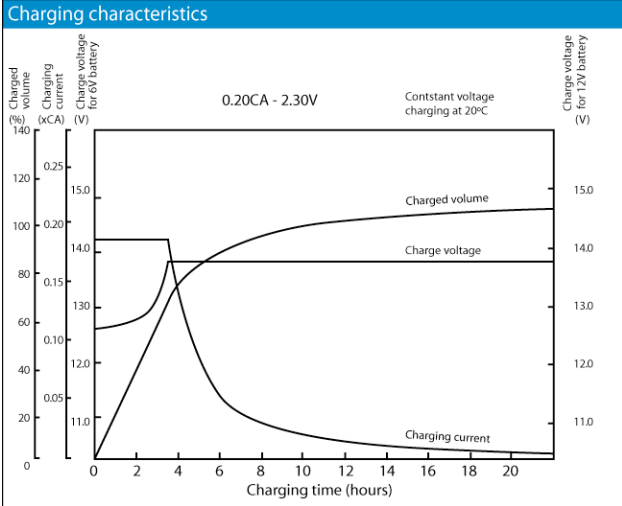

Models available

Model	capacity (Ah)	Dimensions (mm)	weight
CPC 9 - 12	9	151 x 65 x 100	2.6 kg
CPC 10 - 12	10	151 x 65 x 111	3.5 kg
CPC 12 - 12	12	151 x 98 x 101	3.7 kg
CPC 18 - 12	18	181,5 x 77 x 167,5	6 kg
CPC 24 - 12	24	166,5 x 175 x 125	8.9 kg
CPC 24 - 12G	24	166,5 x 175 x 125	8.9 kg
CPC 33 - 12	33	195 x 130 x 180	11.2 kg
CPC 38 - 12	38	197 x 165 x 170	14.5 kg
CPC 55 - 12	55	228 x 138 x 208	19 kg
CPC 60 - 12	60	278 x 175 x 190	21.5 kg
CPC 75 - 12	75	259 x 168 x 208	23.3 kg
CPC 90 - 12	90	330 x 173 x 212	29 kg
CPC 110 - 12	110	330 x 173 x 220	31 kg
CPC 120 - 12	120	410 x 177 x 225	35 kg
CPC 135 - 12	135	344 x 171 x 280	46,3 kg
CPC 150 - 12	150	485 x 170 x 242	43 kg
CPC 160 - 12	160	530 x 209 x 214	41 kg
CPC 200 - 12	200	522 x 240 x 224	61 kg

VdS approved VRLA batteries:

The VdS-approved Cellpower batteries form a special range that has been tested and qualified by the German VdS institute. The concept behind VdS recognition; ensuring tested and certified quality in the products and services being offered in the safety and security markets, is of equally advantageous for user and supplier.

Safety and security systems are approved by the VdS and monitored in subsequent use to protect property and life and help to keep an insurance premium lower.

Apart from the VdS approval, this range is also approved by the Dutch NCP institute, further underlining the high quality of this range.

Typical applications:

- VdS & NCP approved alarm systems
- Fire & burglar alarm systems