

CP 65-12I

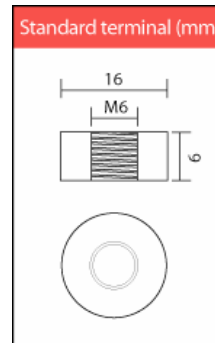

**Battery for multi purpose use**

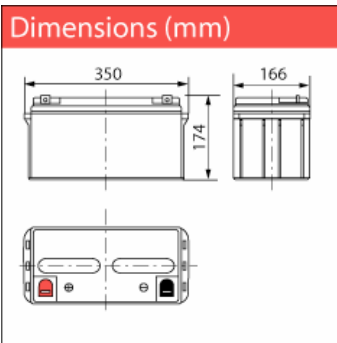

Nominal voltage	12 V	
Nominal Capacity (20HR,20°C):	65 Ah	
Internal resistance	Approx. 6 m Ω	
Maximum charging current	19,5 A	
Maximum discharge current	650 A (5 sec.)	
Operating temperature range	-20°C ~ 50°C	
Float use/ cycle use	13,6 - 13,8V/ 14,5 – 14,9V	
Expected life (20°C)	3 – 5 years in float charge	
Standard terminal	Threaded insert 6 mm	
Housing material	ABS	
Dimensions	length	348 mm
	width	167 mm
	height	178 mm (±1 mm)
Approx. Weight	22 kg	
Packing	1 /box	

- Typical applications:**
- Alarm devices
  - Measuring equipment
  - Emergency lightning
  - Medical equipment
  - Telecommunication systems
  - UPS systems
  - Toys
  - Domestic applications.

- Valve Regulated Maintenance Free
- High current drain grid being resistant to corrosion by virtue of a lead-calcium alloy
- Absorbent Glassmat Technology (AGM)
- Classified as non- spillable and Non Dangerous goods by IATA, FAA, ADR, IMDG
- Can be discharged or stored in any position without leakage
- Cannot be charged while the terminal is downward

**Constant Current Discharge Characteristics (A, 20°C)**

F.V/TIME	5min	10min	15min	30min	60min	3h	5h	10h	20h
9.60V	224	161	126	78	49	20	14,4	8,3	4,3
10.2V	200	144	114	71	44	19	13,3	7,7	4,3
10.8V	178	128	102	64	39	18	12,4	7,2	3,8

**Constant Power Discharge Characteristics (Watt, 20°C)**

F.V/TIME	5min	10min	15min	30min	60min	3h	5h	10h	20h
9.60V	2153	1544	1208	752	467	196	138	79.4	41.4
10.2V	2045	1467	1159	722	449	194	136	78.8	41.4
10.8V	1922	1379	1102	686	426	191	134	77.6	40.8

## Charging characteristics

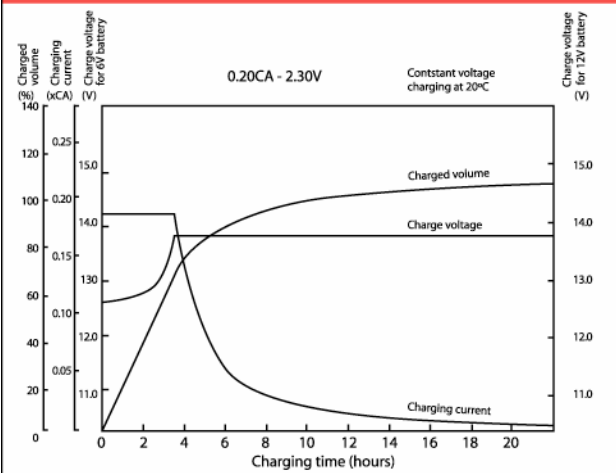

## Discharge characteristics curves

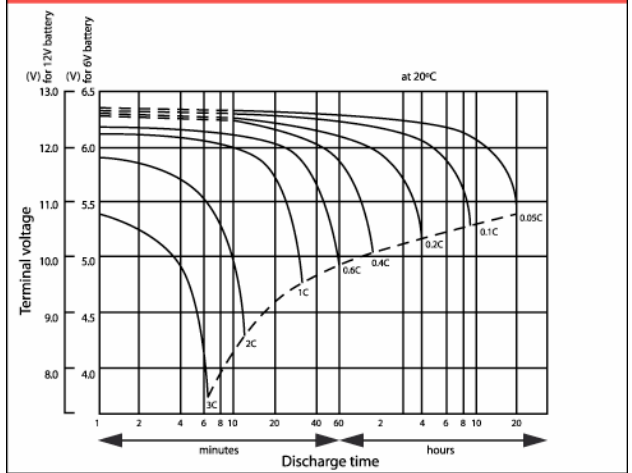

## Relationship between charging voltage and temperature

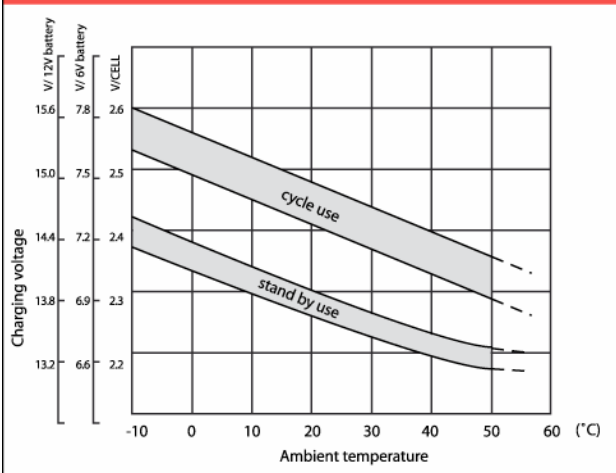

## Cycle service life in relation to depth and discharge

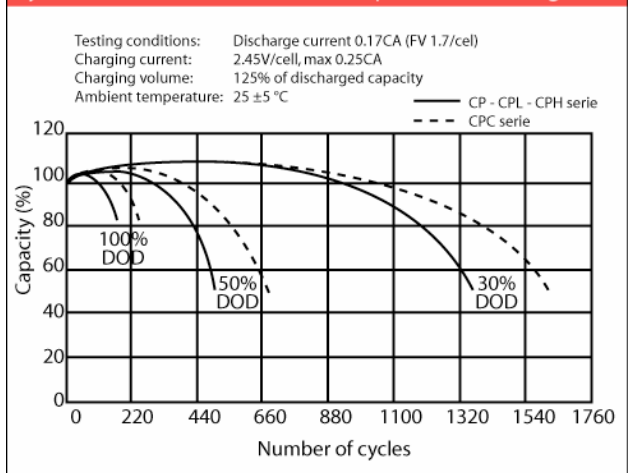

## Models available

Model	capacity (Ah)	Dimensions (mm)	weight
CP 1.2 - 6	1.2	97 x 24 x 58	0.31 kg
CP 4 - 6	4	70 x 47 x 107	0.75 kg
CP 7 - 6	7	151 x 34 x 100	1.36 kg
CP 12 - 6	12	151 x 50 x 100	2.1 kg
CP 12 - 6L	12	151 x 50 x 100	2.1 kg
CP 0.8 - 12	0.8	96 x 25 x 62	0.34 kg
CP 1.2 - 12	1.2	97 x 43 x 58	0.61 kg
CP 2 - 12M	2	150 x 20 x 90	0.68 kg
CP 2.3 - 12	2.3	178 x 35 x 67	0.99 kg
CP 2.3 - 12C	2.3	182 x 24 x 62	0.71 kg
CP 2.9 - 12	2.9	79 x 56 x 105	1.1 kg
CP 3.2 - 12	3.2	134 x 67 x 67	1.4 kg
CP 4.5 - 12	1.2	195 x 47 x 74	1.6 kg
CP 5 - 12	5	90 x 70 x 107	1.98 kg
CP 7 - 12	7	151 x 65 x 100	2.66 kg
CP 7 - 12L	7	151 x 65 x 100	2.66 kg
CP 12 - 12	12	151 x 98 x 101	3.7 kg
CP 18 - 12I	18	181 x 77 x 167	5.7 kg
CP 20 - 12B	20	181 x 77 x 167	5.8 kg
CP 24 - 12I	24	166 x 175 x 125	8.2 kg
CP 38 - 12I	38	197 x 165 x 170	13.8 kg
CP 45 - 12I	45	197 x 165 x 170	14.5 kg
CP 65 - 12I	65	348 x 167 x 178	22 kg

## VdS approved VRLA batteries:

The VdS-approved Cellpower batteries form a special range that has been tested and qualified by the German VdS institute. The concept behind VdS recognition; ensuring tested and certified quality in the products and services being offered in the safety and security markets, is of equally advantageous for user and supplier.

Safety and security systems are approved by the VdS and monitored in subsequent use to protect property and life and help to keep insurance premiums lower.

Apart from the VdS approval, this range is also approved by the Dutch NCP institute, further underlining the high quality of this range.

## Typical applications:

- VdS & NCP approved alarm systems
- Fire & burglar alarm systems